

BERNARDO®

www.bernardo.at



01 | 2024

MISCELLANEOUS



RT 2
RT 3 T
RT 3 F

Router table

RT 2

- Standard with T-slot (19 mm) in the work table for attaching angle stops or various clamping devices
- Assembly of the router on the underside of the table top, mounting holes must be drilled by yourself
- Integrated suction connection for connecting a dust collector for a dust-free workplace
- Worktable made of plastic-coated 36 mm thick MDF table top
- Grooved insert plate (Bakelite) incl. 2 insert rings results in 3 hole sizes
- Including torsion-resistant moulding fence with measuring scales and T-slots (8 mm)
- Suitable for all common routers



Incl. 2 insert rings (diam. 67/32 mm) and free milling stop for milling various shapes.



Plastic-coated MDF moulding fence with T-slots and cutter protection.



2 pcs. adapter (70 or 63 mm) included at standard accessories.



BERNARDO
www.bernardo.at
HOBBY

**Best
Price**



Standard accessories:

- Moulder fence
- MDF stop
- Aluminium stop
- Insert plate 306 x 229 x 9 mm
- Measuring scales
- Guide pin
- Table insert rings
- Stand

Technical data

RT 2

Table size	800 x 605 mm
Table thickness	36 mm
Table height	860 mm
MDF stop	(2 pcs.) 458 x 152 x 25 mm
Aluminium stop	840 x 100 x 100 x 6 mm
Table opening	98 mm
Insert rings	67/ 32 mm
Dust extraction outlet	70 / 63 mm
Machine dimension (W x D x H)	950 x 605 x 1010 mm
Weight approx.	26 kg
Art. no.	14-2215

- Suitable for all common routers
- Tilttable work table for easier mounting of the router
- Torsion-free, grey cast-iron machine table for maximum accuracy
- Solid moulding fence features anodized stop bars
- Incl. longitudinal groove in the work table for attaching the mitre fence, spring clamps, etc.
- With suction connection diam. 100 mm for the use of a dust collector
- Attractive price-benefit ratio

BERNARDO
www.bernardo.at

SEMIPROFESSIONAL

Best price



Moulding fence with dust extraction outlet 100 mm, 2 adjustable aluminium stops and pressing device

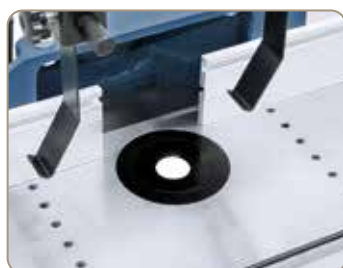

Standard with insert rings to reduce the table opening.



Mitre fence moveable along entire table length.



For easier mounting of the router, the table can be tilted up.



Technical data

RT 3 T

Table size	780 x 505 mm
Table tilttable	0° - 45°
Table height	860 mm
Aluminium stop	2x 300 x 75 mm
Table opening	92 mm
Insert rings	60 / 30 mm
Dust extraction outlet	100 mm
Machine dimension (W x D x H)	880 x 675 x 1125 mm
Weight approx.	57 kg
Art. no.	14-2216

Standard accessories:

- Moulder fence
- Mitre fence
- Pressing device
- Table insert rings
- Stand

Router table

RT 3 F

- Suitable for all common routers
- Tilttable work table for easier mounting of the router
- Vibration-free working due to stable cast steel construction
- Smooth sliding table for easy processing of large workpieces
- Robust moulding fence with finely adjustable aluminium stop bars
- With suction connection diam. 60 mm for the use of a dust collector
- Ideal for craftsmen and home users

BERNARDO
www.bernardo.at
SEMIPROFESSIONAL



For easier mounting of the router, the table can be tilted up.



Spindle moulding fence comes complete with fine adjustment. Integrated dust outlet ensures proper dust removal.



Moveable fence with downholder



Inclusive sliding table

Best Price



Standard accessories:

- Sliding table
- Moulder fence
- Pressing device
- Table insert rings
- Fence with downholder
- Stand

Technical data

RT 3 F

Table size	785 x 505 mm
Sliding table	785 x 310 mm
Table tilttable	0° - 45°
Table height	860 mm
Aluminium stop	2x 300 x 75 mm
Table opening	92 mm
Insert rings	60 / 29 mm
Dust extraction outlet	60 mm
Machine dimension (W x D x H)	1020 x 780 x 1100 mm
Weight approx.	55 kg
Art. no.	14-2217

Universal stand

KSU 740

- Optimal for mitre saws, but also for small bandsaws, sanding machines.....
- Foldable for easy transport or space saving storage
- Workpiece support extractable up to 2000 mm, optimal for applying of long workpieces
- Ideal stand for the assembly and construction site use
- Ergonomic work through height adjustable workpiece supports (710 - 850 mm)
- Mounting rails with quick clamping comes standard
- Solid construction with low weight



Example of use with belt and disc sander



**Best
Price**

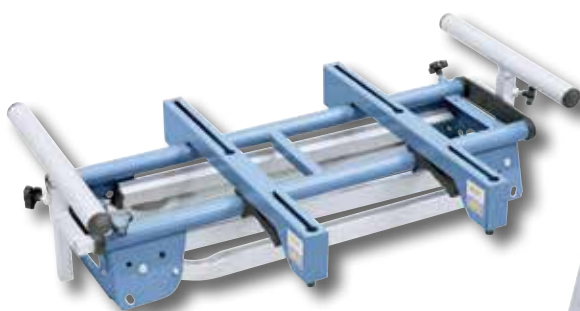

Space saving, quick and easy foldable



Picture show standard accessories

Technical data **KSU 740**

Working length	820 - 2000 mm
Working height	710 - 850 mm
Load capacity max.	120 kg
Machine dimension (W x D x H)	910 x 540 x 710 mm
Dimension folded	900 x 500 x 210 mm
Weight approx.	10 kg
Art. no.	07-1536

Standard accessories:

- Height adjustable workpiece supports
- Mounting rail set (2 pcs.)

Universal stand

KSU 1100

- Roller support with tiltable end stops stepless extractable
- Optimal for mitre saws, but also for small bandsaws, sanding machines.....
- Foldable for easy transport or space saving storage
- Ergonomic work through height adjustable workpiece supports (900 - 1145 mm)
- Optimal for applying of long workpieces, solid construction (max. load capacity 150 kg)
- Ideal stand for the assembly and construction site use
- Mounting rails with quick clamping comes standard
- Including rollers for easy transport



The moveable mounting rails can be adjusted quickly and easily to the machine width



Roller supports stepless extractable and height adjustable on both sides



Easy relocation through big dimensioned rollers.

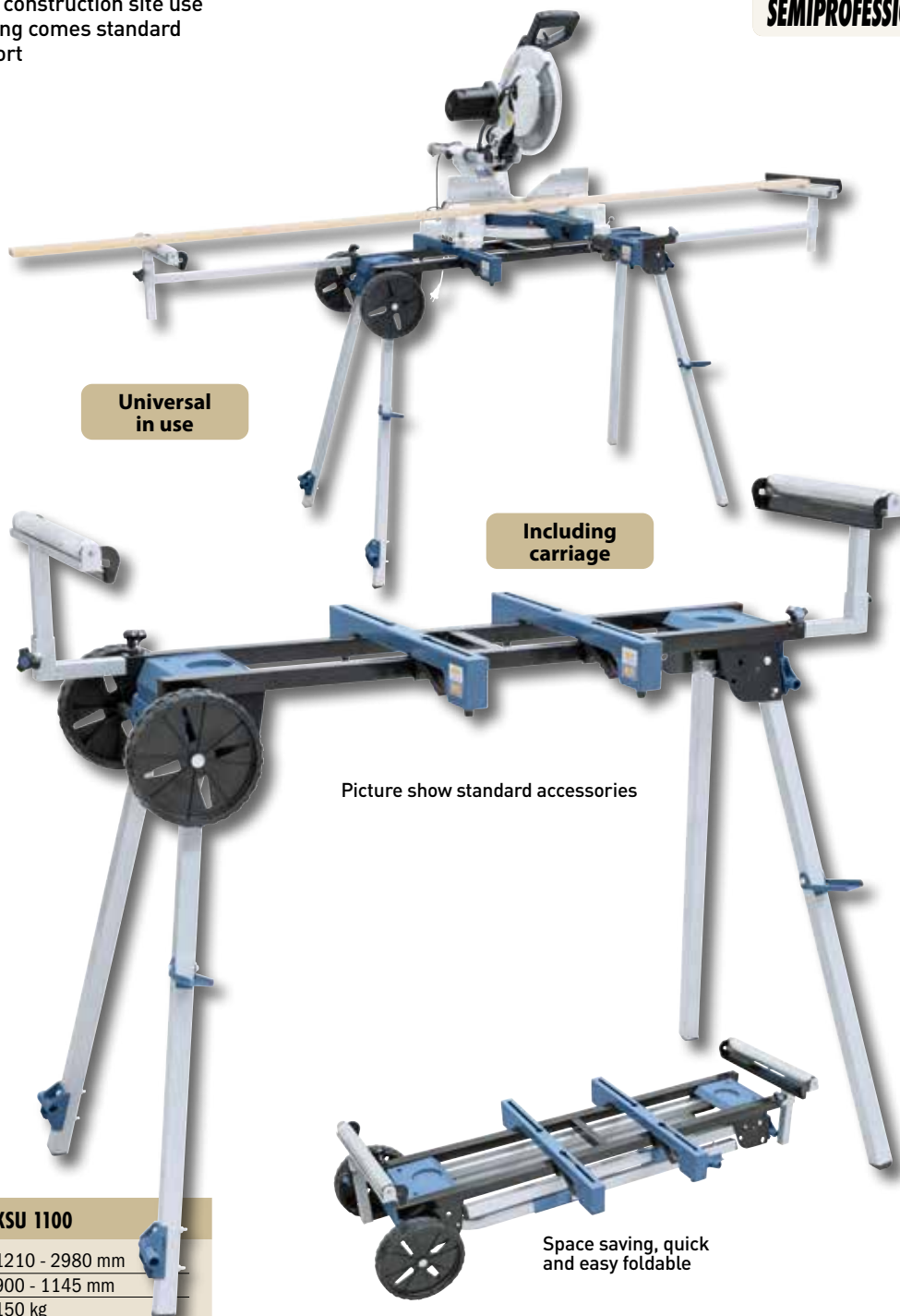

Universal in use

Including carriage

Picture show standard accessories

Space saving, quick and easy foldable

Technical data	KSU 1100
Working length	1210 - 2980 mm
Working height	900 - 1145 mm
Load capacity max.	150 kg
Machine dimension (W x D x H)	1320 x 670 x 900 mm
Dimension folded	1300 x 530 x 300 mm
Weight approx.	17 kg
Art. no.	07-1537

Standard accessories:

- Height adjustable workpiece supports
- Mounting rail set (2 pcs.)
- Carriage

- Roller supports stepless extractable and height adjustable on both sides
- Robust aluminium-steel construction with low weight
- Universal useable for table saws, mitre saws, sanding machines, etc.
- Compact transport dimension due to foldable construction
- Wide range of accessories comes standard
- Ideal stand for the assembly and construction site use
- Easy relocation through big dimensioned roller.



Serially with integrated plug sockets 230 V (3 pcs.)



The moveable mounting rails can be adjusted quickly and easily to the machine width



Vice with quick clamping comes standard.

Including carriage

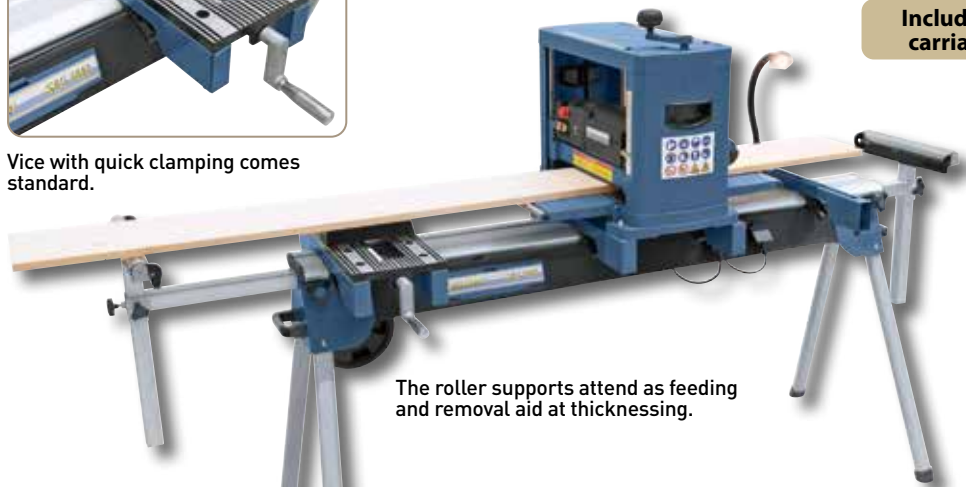

The roller supports attend as feeding and removal aid at thickening.



Optimal for single and series work, roller supports as standard with tiltable end stops.

Universal in use



Picture show standard accessories

Technical data	KSU 1560
Working length	1400 - 2900 mm
Working height	815 - 1190 mm
Load capacity max.	250 kg
Machine dimension (W x D x H)	1800 x 700 x 815 mm
Dimension folded	1800 x 700 x 250 mm
Weight approx.	28 kg
Art. no.	07-1538

Standard accessories:

- Roller support with tiltable end stop (2 pcs.)
- Work light with mounting rail
- Vice with quick clamping
- Mounting rail set (2 pcs.)
- Plug socket 230 V (3 pcs.)
- Carriage

Universal carriage

MB 230

- Optimal for bandsaws, sanding machines, planer machines, drilling machines, etc.
- Swivel castors can be rotated 360 ° for easy maneuverability
- Many different size adjustments due to the breadboard
- For easy transport and relocation
- Serially with 2 pcs. steering roller and wedging brake
- Quick and easy assembling
- Safe and stable construction



Serially equipped with steering wheel and locking brake.



**Universal
in use**

**Best
Price**

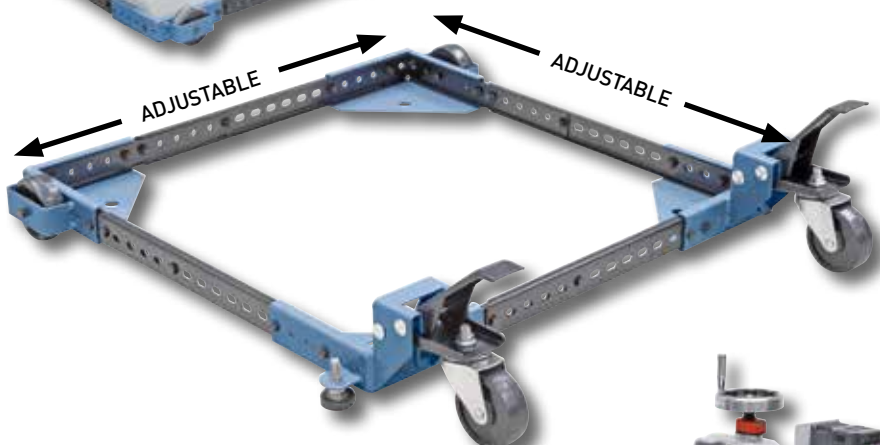

BERNARDO
www.bernardo.at
SEMIPROFESSIONAL



Technical data	MB 230
Minimal size square	280 x 280 mm
Maximal size square	900 x 900 mm
Minimal size rectangular	530 x 280 mm
Maximal size rectangular	900 x 640 mm
Hole spacing	25 mm
Capacity max.	300 kg
Weight approx.	8 kg
Art. no.	56-10700

- Standard accessories:**
- 2 pcs. steering wheel
 - Locking brake

Universal carriage

MB 400

- Optimal for bandsaws, sanding machines, planer machines, drilling machines, etc.
- Swivel castors can be rotated 360° for easy maneuverability
- Many different size adjustments due to the breadboard
- For easy transport and relocation
- Serially with 2 pcs. steering roller and wedging brake
- Quick and easy assembling
- Safe and stable construction

**Best
Price**



Serially equipped with steering wheel and locking brake.

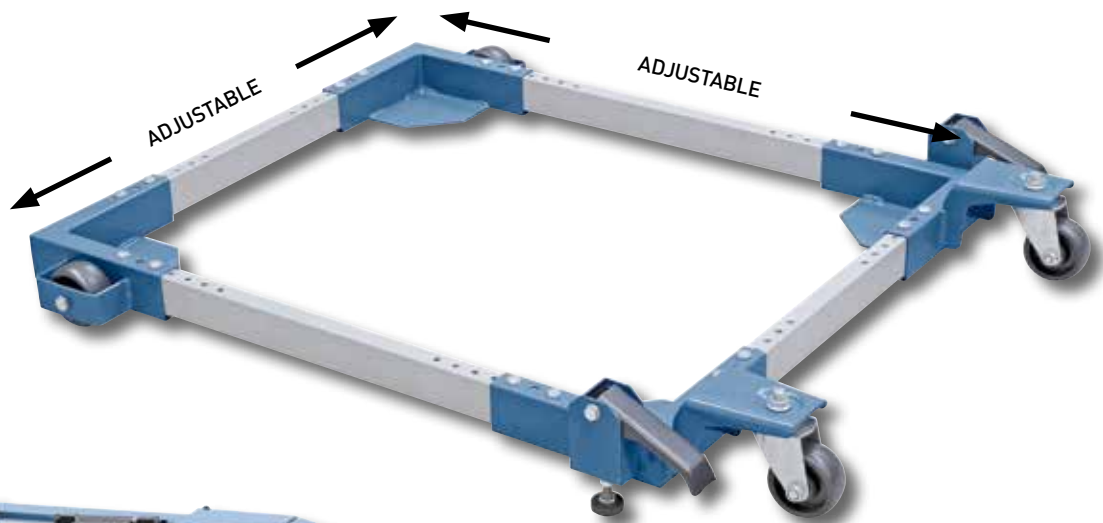

**Universal
in use**

Technical data	MB 400
Minimal size square	620 x 620 mm
Maximal size square	730 x 730 mm
Minimal size rectangular	660 x 480 mm
Maximal size rectangular	860 x 730 mm
Hole spacing	25 mm
Capacity max.	500 kg
Weight approx.	13,5 kg
Art. no.	56-10702

- Standard accessories:**
- 2 pcs. steering wheel
 - Locking brake

Roller stands

- Ideal support for resting of long and heavy workpieces
- Large variety of models for all types of applications
- Universally applicable, for instance metal circular saws, bandsaws, wood working machines etc.

FRS-Serie RS-Serie



FRS-1



CFRS-8



KFRS-8

Technical data	FRS-1	CFRS-8	KFRS-8
Roller width	400 mm	400 mm	420 mm
Roller diameter	57 mm	57 mm	-
Height adjustment	675 - 1000 mm	670 - 995 mm	630 - 955 mm
Load capacity max.	80 kg	80 kg	70 kg
Stand pipe diam.	30 mm	30 mm	30 mm
Weight approx.	5 kg	6 kg	6 kg
Art. no.	07-1401	07-1402	07-1403
Price excl. VAT			

- Foldable model**
- Foldable design keeps space requirements to a min
 - Light-weight construction ensures convenience when frequently transported
 - Model CFRS-8 can be used with roller or ball support depending on type of application
 - Model KFRS-8 comes complete with angle adjustment for ideal support of round workpieces, profiles etc.



LRS



CRS



KRS

Technical data	LRS	CRS	KRS
Roller width	400 mm	400 mm	400 mm
Roller diameter	57 mm	50 mm	-
Height adjustment	665 - 1145 mm	685 - 1170 mm	700 - 1110 mm
Load capacity max.	100 kg	100 kg	90 kg
Stand pipe diam.	57 / 40 mm	57 / 40 mm	57 / 40 mm
Weight approx.	8 kg	8 kg	7,5 kg
Art. no.	07-1400	07-1420	07-1425
Price excl. VAT			

- Stable model**
- Roller support features stepless height adjustment and clamping option
 - Model CRS can be used with roller or ball support depending on type of application
 - Modell KRS features 8 chromium plated caster wheels, suitable for movements in any direction

Roller tables

- Solid, resilient galvanized steel rollers ensure for secure support of workpiece
- Roller support features stepless height adjustment and can be clamped
- Straightforward and efficient transport of materials for the infeed and outfeed of workpieces

RB 2

RB 3



RS



VRS

Technical data

	RS	VRS
Roller width	350 mm	2 x 125 mm
Roller diameter	51 mm	51 mm
Height adjustment	575 - 975 mm	560 - 975 mm
Load capacity max.	700 kg	700 kg
Stand pipe diam.	74 / 52 mm	74 / 52 mm
Weight approx.	20 kg	20 kg
Art. no.	07-1405	07-1415
Price excl. VAT		

Heavy construction

- Heavy tripod construction designed for heavy workloads
- Roller rest features height adjustment and can be clamped
- Solid, resilient galvanized steel rollers offer secure support of each workpiece
- VRS- roller stand complete with two rollers at 125 mm in length, ideal for pipes,...

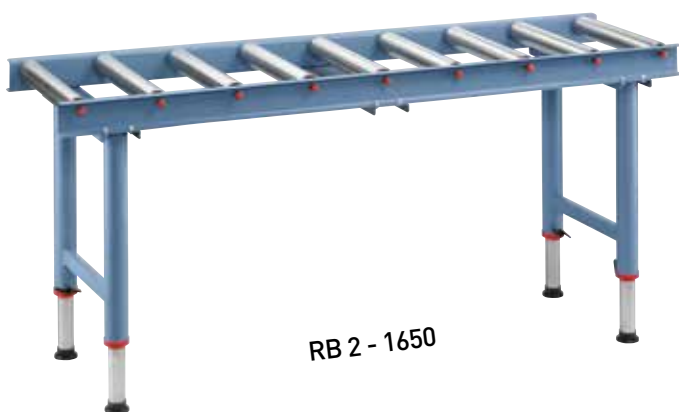

RB 2 - 1650

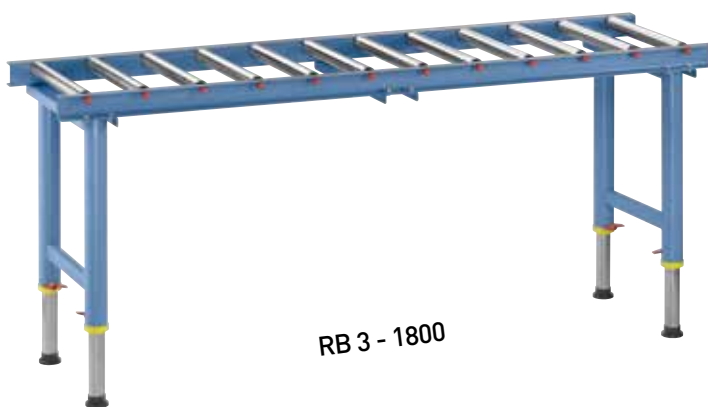

RB 3 - 1800

Technical data

	RB 2 - 1650	RB 3 - 1800
Path length	1650 mm	1800 mm
Roller width	395 mm	410 mm
Roller diameter	57 mm	38 mm
Height adjustment	665 - 1140 mm	640 - 1110 mm
Load capacity max.	500 kg	500 kg
Stand pipe diameter	40 mm	40 mm
Weight approx.	29 kg	27 kg
Art. no.	07-1455	07-1460
Price excl. VAT		

Roller tables – light weight construction

- Frames of rollers consist of solid U-shaped profile
- Ball bedded steel rollers on both sides allow for heavy workloads
- Machine feet can be height adjusted individually to allow for ideal adjustment to machine height and to make up for floor unevenness

Hobelmesser HSS	Spiralmesser-Hobelwelle	HM-Wendeplatten für Spiralmesser	Drehmoment-Schraubendreher 6 Nm
Planer knives HSS	Spiral cutter block	TCT-blades for spiral cutter	Torque wrench 6 Nm
			
Diverse Abmessungen von 205 mm bis 630 mm erhältlich Different dimensions from 205 mm to 630 mm available	Verminderung der Lärmbelastung (ca. 50%) und bis zu 20-fache Schneidenstandzeit Reduction of noise level (approx. 50%) and up to 20 times the cutting edge life	15 x 15 x 2,5 mm / Fixierschrauben: M6 x 15 15 x 15 x 2,5 mm / Fixierschrauben: M5 x 12 15 x 15 x 2,5 mm / Fixing screws: M6 x 15 15 x 15 x 2,5 mm / Fixing screws: M5 x 12	Zum richtigen fixieren der HM-Wendeschneidplatten für die Spiralmesser-Hobelwelle Torque wrench for correctly fixing of the TCT-blades for the spiral cutter
Hobelmessereinstellehre HML	Westcott - Bohrfutter	Kopiereinrichtung	Kopiereinrichtung Deluxe
Planer knives adjustment HML	Westcott chuck	Copying device	Copying device Deluxe
			
2 Stk. magnetische Einstellehren in Holzkassette 2 pcs. magnetic adjust gauge, packed in wooden case	Spannbereich: 0 - 16 mm Spannbereich: 0 - 20 mm Clamping range: 0 - 16 mm Clamping range: 0 - 20 mm	Zum Kopieren vom Originalteil oder nach Schabole, Kopierlänge 850 mm copying device for copying of original parts ore templates, Copying length 850 mm	Zum Kopieren vom Originalteil oder nach Schabole, Kopierlänge 1200 mm copying device for copying of original parts ore templates, Copying length 1200 mm
Absaugung für Drechselmaschinen	Universal-Untergestell ULEG	Verlängerung für ULEG	Spannzangenset M 24 / M 33, 6 tlg.
Sweeper for woodturning lathe	Universal-stand ULEG	Extension for ULEG	Collet chuck system M 24 / M 33, 6 pcs.
			
Absauganschluss: 100 mm Höhenverstellbar Dust extraction outlet: 100 mm Height adjustable	Arbeitslänge: 535 - 910 mm Arbeitshöhe: 635 - 865 mm Working length: 535 - 910 mm Working height: 635 - 865 mm	Arbeitslänge: 500 - 870 mm Arbeitshöhe: 635 - 865 mm Working length: 500 - 870 mm Working height: 635 - 865 mm	Spannzangen: 6 / 10 / 12 / 16 mm / 5,8" Collets: 6 / 10 / 12 / 16 mm / 5,8"
Mitnehmerset M 33 x 3,5, 7-tlg.	Mitnehmerset M 33 x 3,5, 9-tlg.	Handauflagen-Set 4 tlg.	4-Backen-Planscheibe 150 mm
Drive center set M 33 x 3,5 - 7 pcs.	Drive center set M 33 x 3,5 - 9 pcs.	Glide bowl turner´s toolrest set 4 pcs.	4-jaw independent chuck 150 mm
			
Gewinde M33 x 3,5 mm, je 3 Stk. Vierzack- und Vielzackmitnehmer Thread M33 x 3,5 mm, each 3 pcs. 4 tooth and multi tooth drive center	Gewinde M33 x 3,5 mm, inkl. 2 Rollkörner MK 1 und MK 3 Thread M33 x 3,5 mm, incl. 2 live center MT 1 and MT 2center	Handauflagenset für verschiedenste Bearbeitungsvorgänge Glide bowl turner´s toolrest set for a wide variety of machining operations	Gewinde M33, Backen einzeln verstellbar Thread M33, jaws separately adjustable

4-Backenspannfutter	3-Backenspannfutter	Selbstzentrierendes Spannfutter	System-Spannfutterset 6-tlg.
4-jaw chuck	3-jaw chuck	Self-centering chuck	6 pcs. power chuck set
			
<p>Durchmesser 125 mm bzw. 150 mm Gewinde M33, zentrisch spannend Diameter 125 mm or 150 mm Thread M33, centric clamping</p>	<p>Durchmesser 125 mm bzw. 150 mm Gewinde M33, zentrisch spannend Diameter 125 mm or 150 mm Thread M33, centric clamping</p>	<p>Spannbereich: 40 - 70 mm Gewinde M33 Range: 40 - 70 mm Thread M33</p>	<p>Viele Spannmöglichkeiten Various clamping possibilities</p>
Spannfutter M 70	Spannfutter M 95	Spannfutter M 115	Spannfutter-Set Premium M 70
Chuck M 70	Chuck M 95	Chuck M 115	Power chuck set Premium M 70
			
<p>Durchmesser 70 mm, Gewinde 1"x8TPI mit Schwalbenschwanzbacken Typ A Diameter 70 mm, thread 1"x8TPI with dovetail jaws type A</p>	<p>Durchmesser 95 mm, Gewinde M33 mit Schwalbenschwanzbacken Typ A Diameter 95 mm, thread M33 with dovetail jaws type A</p>	<p>Durchmesser 115 mm, Gewinde M33 mit Schwalbenschwanzbacken Typ A Diameter 115 mm, thread M33 with dovetail jaws type A</p>	<p>Durchmesser 70 mm, Gewinde 1"x8TPI inkl. 5 verschiedene Backen Diameter 70 mm, thread 1"x8TPI incl. 5 different jaws</p>
Spannfutter-Set Premium M 95	Spannfutter-Set Premium M 115	Profi-Drechselmessersatz A	Profi-Drechselmessersatz B
Power chuck set Premium M 95	Power chuck set Premium M 115	Profi-chisel set A	Profi-chisel set B
			
<p>Durchmesser 95 mm, Gewinde M33 inkl. 5 verschiedene Backen Diameter 95 mm, thread M33 incl. 5 different jaws</p>	<p>Durchmesser 115 mm, Gewinde M33 inkl. 5 verschiedene Backen Diameter 115 mm, thread M33 incl. 5 different jaws</p>	<p>HSS, 6-tlg. Heftlänge: 340 / 300 / 255 mm HSS, 6 pcs. Handle length: 340 / 300 / 255 mm</p>	<p>HSS, 8-tlg. Heftlänge: 240 mm HSS, 8 pcs. Handle length: 240 mm</p>
Standard-Drechselmessersatz C	Starter-Drechselmessersatz D	Mini-Drechselmessersatz E	Mini-Drechselmessersatz F
Standard-chisel set C	Starter-chisel set D	Mini-chisel set E	Mini-chisel set F
			
<p>Carbon, 6-tlg. Heftlänge: 340 / 300 / 255 mm Carbon, 6 pcs. Handle length: 340 / 300 / 255 mm</p>	<p>HSS, 5-tlg. Heftlänge: 440 / 410 / 300 / 255 mm HSS, 5 pcs. Handle length: 440 / 410 / 300 / 255 mm</p>	<p>HSS, 5-tlg. Heftlänge: 160 mm HSS, 5 pcs. Handle length: 160 mm</p>	<p>HSS, 3-tlg. Heftlänge: 200 mm HSS, 3 pcs. Handle length: 200 mm</p>

Schleifscheiben SBS 700 / 800 / 1000	Schleifbandreiniger	Filtersack	Absaug sack
Sanding discs SBS 700 / 800 / 1000	Belt cleaner	Filter bag	Waste bag
			
Diamantschleifscheibe SBS 700 / 1000 Schleifscheibe für SBS 400 Diamond grinding wheel 125 x 10 x 13 mm Corundum grinding wheel 125 x 10 x 13 mm	Erhöht die Standzeit von Schleifbändern und Schleifhülsen Increase the lifetime of sanding belts and sanding discs	Für sämtliche BERNARDO Absauganlagen For all BERNARDO dust collectors	Für sämtliche BERNARDO Absauganlagen For all BERNARDO dust collectors
Reinluftfilterpatrone FP 1	Reinluftfilterpatrone FP 2	Reinluftfilterpatrone FP 3	Adapter
Cartridge filter FP 1	Cartridge filter FP 2	Cartridge filter FP 3	Adapter
			
Durchmesser: 370 mm / Höhe: 490 mm Filterfläche: 2,25 m ² Diameter: 500 mm / Height: 490 mm Filter area: 2,25 m ²	Durchmesser: 500 mm / Höhe: 590 mm Filterfläche: 4 m ² Diameter: 500 mm / Height: 590 mm Filter area: 4 m ²	Durchmesser: 500 mm / Höhe: 1220 mm Filterfläche: 8 m ² Diameter: 500 mm / Height: 1220 mm Filter area: 8 m ²	Aussendurchmesser: 100 - 70 / 65 - 45 / 40 - 40 / 35 - 35 Outside diameter: 100 - 70 / 65 - 45 / 40 - 40 / 35 - 35
Y-Abzweigung	PVC-Spiralabsaugschlauch	PU-Spiralabsaugschlauch	Erdungsset ES 1
Y-Divergency	PVC-tube	PU-tube	Grounding set ES 1
			
Ø 130 mm auf 2x 100 mm Ø 150 mm auf 3x 100 mm Ø 130 mm to 2x 100 mm Ø 150 mm to 3x 100 mm	Durchmesser 100 mm Länge 4 m bzw. 10 m Diameter 100 mm Länge 4 m or 10 m	Durchmesser / Diameter: 60 / 80 / 100 / 120 / 160 / 180 mm Länge / Length: 4 / 6 / 10 m	Schützt die Absauganlage vor Feuer- und Explosionsgefahr Protect the dust collector against the risk of fire and explosion
Einschaltautomatik ALV 2 / M 230	Einschaltautomatik ALV 10 / 1 M	Vorschubrollen	Vorschubabklappeinrichtung FP/01
Automatic start-up ALV 2 / M 230	Automatic start-up ALV 10 / 1 M	Rolls for power feeders	Flipper FP-01
			
Schaltvermögen AC-1: 230 V / 10A Schaltvermögen AC-3: 230 V / 4A Breaking capacity AC-1: 230 V / 10A Breaking capacity AC-3: 230 V / 4A	Für Maschinen bis 4,0 kW Motorleistung mit 230 V bzw. 400 V For machines up to 4,0 kW motor power with 230 V or 400 V	Verschiedene Vorschubrollen Ø 76 / 80 / 100 / 120 Different rolls for power feeders Ø 76 / 80 / 100 / 120	Zeitsparend, keine Demontage des Vorschubapparates nötig Time saving, no disassembling of the power feed necessary

Hohlstemböhrer	Langlochbohrer-set 6-tlg.	Tischler-Set 3-tlg.	Tischler-Set 5-tlg.
Mortising chisels	Mortising bit set 6 pcs.	Woodworking kit 3 pcs.	Woodworking kit 5 pcs.
			
Größen / Sizes: 6,35 / 8,0 / 9,5 / 12,7 / 15,87 19,0 / 25,4 mm	∅ 6 / 8 / 10 / 12 / 14 / 16 mm Rechts- bzw. linksschneidend ∅ 6 / 8 / 10 / 12 / 14 / 16 mm Clock- and counterclockwise	Unerlässlich für Tischlerarbeiten Necessary for carpenter works	Unerlässlich für Tischlerarbeiten Necessary for carpenter works
Gleitmittel Waxilit	Vorritzsägeblatt	Sägeblattset im Alukoffer, 3-tlg.	Sägeblattset im Alukoffer, 3-tlg.
Lubricant Waxilit	Scoring sawblade	TCT sawblade set in aluminium case	TCT sawblade set in aluminium case
			
Unerlässlich in der Holzbearbeitung Essential in the area of woodworking	Durchmesser: 80 / 90 / 120 mm Diameter: 80 / 90 / 120 mm	Durchmesser / diam: 250 mm Zähne / teeth: 24 / 60 / 80 Bohrung / hole: 30 mm Reduzierring / reducing ring: 25,4 / 20 mm	Durchmesser / diam. 315 mm Zähne / teeth: 28 / 48 / 72 Bohrung / hole: 30 mm Reduzierring / reducing ring: 25,4 / 20 mm

Leichtmetall - Hobelkopf	Multiprofilfräser	Trapez-Verleimfräser	Spitzverleimfräser
Cutter head	Multi profile cutter head	Finger joint cutter head	V-glue joint cutter head
			
125 x 130 x 40 mm / 125 x 170 x 40 mm 125 x 210 x 40 mm / 125 x 230 x 40 mm 125 x 240 x 40 mm	120 x 40 x 30 mm 160 x 50 x 30 mm	130 x 60 x 30 mm - Z2	120 x 50 x 30 mm - Z2
Falzmesserkopf	Falzmesserk. m. ziehenden Schneiden	Schwenkmesserkopf	Abplattfräser
Rebating cutter head	Rebating cutter head w. shear angle	Adjustable bevel cutter head	Panel raising cutter head
			
125 x 50 x 30 mm - Z4/V4 150 x 50 x 30 mm - Z4/V4	125 x 50 x 30 mm - Z4/V4 150 x 50 x 30 mm - Z4/V4	120 x 40 x 30 mm - Z2 / 2 x 45°	160 x 17 x 30 mm 180 x 20 x 30 mm
Verstellnutter	Verstellnutter	Universal - Profilmesserkopf	Universal-Profilmesserkopfset
Adjustable groove cutter head	Adjustable groove cutter head	Universal cutter head	Universal cutter head set
			
Mit Zwischenringen 160 x 4 - 7,5 x 30 mm With spacer ring 160 x 4 - 7,5 x 30 mm	Mit Zwischenringen 160 x 12 - 24 x 30 mm With spacer ring 160 x 4 - 7,5 x 30 mm	100 x 40 x 30 mm	100 x 40 x 30 mm Inkl. 7 Messer Incl. 7 Messer
Anlaufringset 12-tlg.			
Butting ring set 12 pcs.			
			
Lieferung in Holzkassette			
Delivered in wooden case			

notes

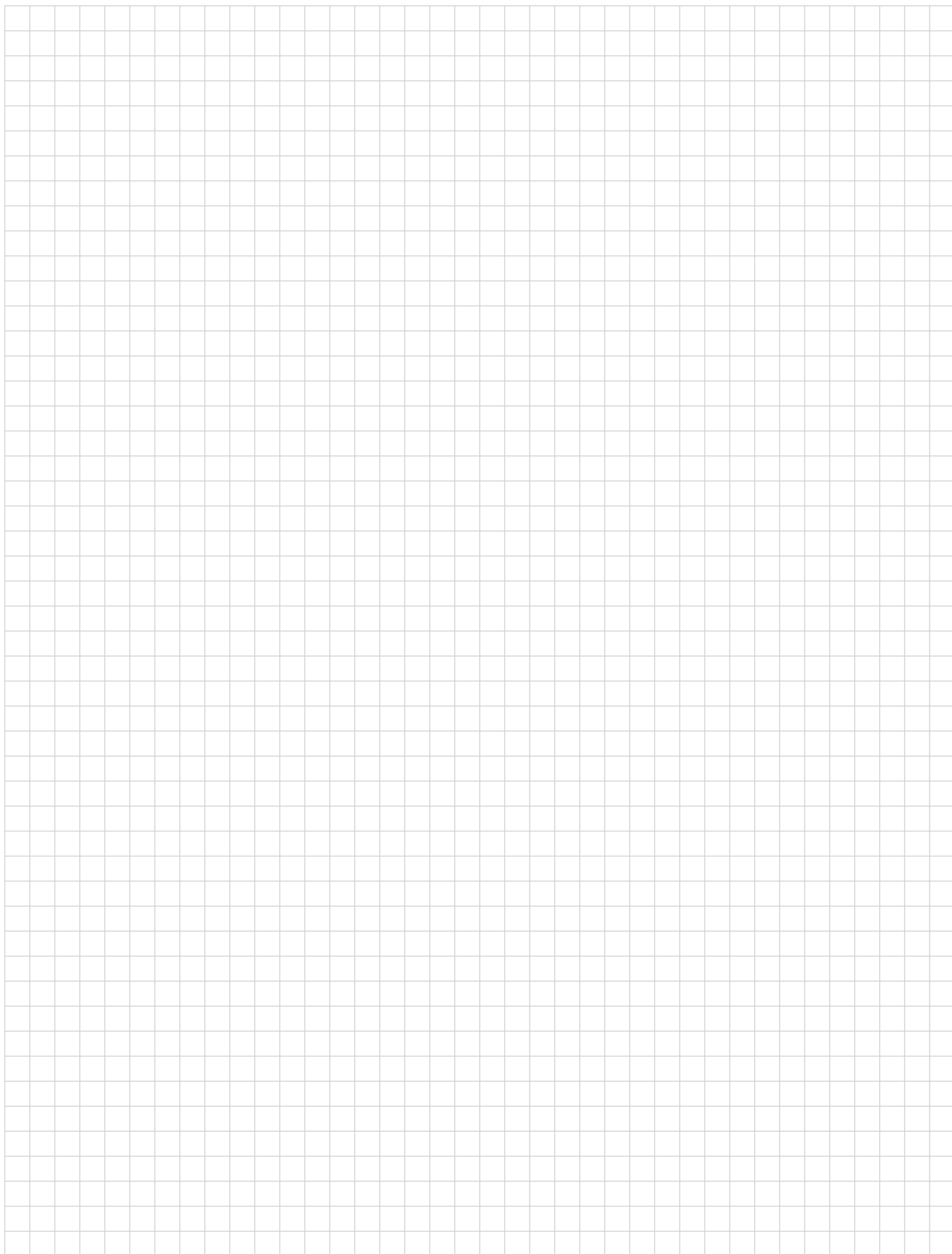

notes

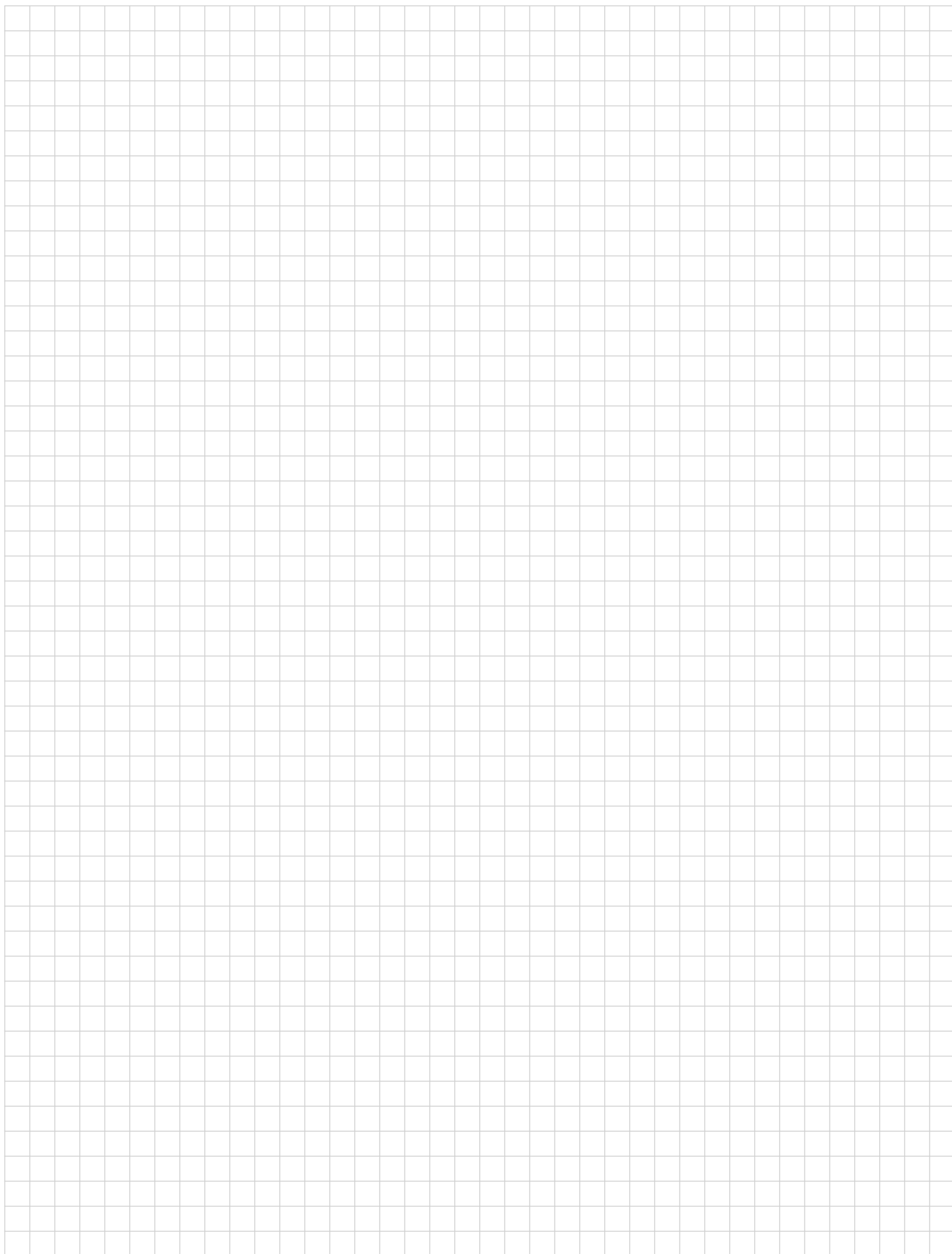

Your dealer

BERNARDO[®]
www.bernardo.at

PWA Handelsges.m.b.H.
4020 Linz | Nebingerstraße 7a | Austria
phone: +43.732.66 40 15 | fax: +43.732.66 40 15-9
e-mail: bernardo@pwa.at | www.bernardo.at