

BERNARDO®

www.bernardo.at

01 | 2024

WOOD BANDSAWS



HBS 230	HBS 800 E
HBS 260	HBS 400 N
HBS 320	HBS 460 N
HBS 360	HBS 500 N
HBS 400	HBS 600 N
HBS 450	HBS 700 N
HBS 510	HBS 800 N
HBS 600 E	BBS 650 B
HBS 700 E	BBS 650 E
	BBS 780 B

Wood bandsaws

HBS-Serie

- Serially with 2 cutting speeds (HBS 320 / HBS 360), ideal for different materials and applications
- Aluminium die casting flywheels with special rubber coating for a long life span of the bandsaw blades
- Buckling resistant, solid sheet metal construction
- Working table out of aluminium (HBS 230 / 260 / 320) resp. cast iron (HBS 360) with tilting device (up to 45°)
- Serially with precision roller guide over and under the table
- Including rip fence and both-sided tiltable mitre fence
- Solid machine stand out of sheet metal for a safe stand at work and ingrated chip tray
- Micro-V-belt drive for an optimal power transmission



The precision bedded aluminium flywheels with rubber-coating guarantee an optimal run of the bandsaw blade.



The integrated loupe at the rip fence afford an exact read-off of the adjusted cutting width.

**Best
Price**



Technical data	HBS 230	HBS 260	HBS 320	HBS 360
Cutting width	225 mm	245 mm	305 mm	345 mm
Cutting height	95 mm	150 mm	170 mm	210 mm
Blade dimension	1575 x 6,35 x 0,35 - 10 TPI	1826 x 10 x 0,35 - 6 TPI	2240 x 12,7 x 0,5 - 4 TPI	2560 x 12,7 x 0,5 - 4 TPI
Blade width	3 - 12,5 mm	6 - 12,5 mm	6 - 20 mm	6 - 25 mm
Cutting speed	635 m/min	760 m/min	370 / 800 m/min	370 / 800 m/min
Table size	300 x 300 mm	360 x 320 mm	480 x 390 mm	545 x 515 mm
Table height	405 mm	930 mm	985 mm	1020 mm
Tilting table	0° to 45°	0° to 45°	0° to 45°	0° to 45°
Dust extraction outlet	50 mm	100 mm	100 mm	100 mm
Motor power output S ₁ 100%	0,30 kW (0,40 HP)	0,37 kW (0,50 HP)	0,75 kW (1,0 HP)	1,1 kW (1,5 HP)
Motor power input S ₆ 40%	0,42 kW (0,57 HP)	0,55 kW (0,75 HP)	1,1 kW (1,5 HP)	1,5 kW (2,0 HP)
Voltage	230 V	230 V	230 V	230 V
Machine dimension (W x D x H)	480 x 370 x 840 mm	650 x 560 x 1430 mm	800 x 600 x 1600 mm	800 x 700 x 1700 mm
Weight approx.	21 kg	32,5 kg	52 kg	70 kg
Art. no.	11-3999	11-4001	11-4002	11-4003
Price excl. VAT				

The wood bandsaws of the HBS-series afford a generous cutting capacity on smallest space. The flywheels are serially equipped with a special rubber-coating whereby a long life-span of the bandsaw blades are warranted. Through the optimale price to performance ratio and efficiency these machines are ideal for the do-it-yourselfer.

HBS-Serie



BERNARDO®
www.bernardo.at
HOBBY

Ball bedded precision guides over and under the table guarantees a perfect bandsaw blade guiding.



Serially with
2 cutting speeds



Standard accessories:

- Bandsaw blade
- Rip fence with loupe (except HBS 230)
- Mitre fence
- Ball-bedded precision blade guiding
- LED working light
- Push stick
- Stand (except HBS 230)

Optional accessories:

	Art. no.	excl. VAT
Bandsaw blade 1575 x 6,35 x 0,5 - 10 TPI for HBS 230	11-1000	
Bandsaw blade 1826 x 6,35 x 0,35 - 6 TPI for HBS 260	11-10030	
Bandsaw blade 1826 x 10 x 0,35 - 6 TPI for HBS 260	11-1003	
Bandsaw blade 2240 x 13 x 0,5 - 4 TPI for HBS 320	11-1002	
Bandsaw blade 2560 x 13 x 0,5 - 4 TPI for HBS 360	11-1007	
Circle cutting device for HBS 260 / 320 / 360	11-4004	
Universal mobile base MB 230	56-10700	

Working lamp and rip fence with loupe comes standard

Wood bandsaws

HBS 400 HBS 450 / HBS 510

- Amply sized working table with grounded surface and T-slot
- Massive cast iron flywheels for smooth run
- Easy adjustable aluminium rip fence with quick clamping system and integrated loupe
- Tilttable working table for mitre cuts from 0° to 45°
- Upper and lower precision roller guiding for precise cuts
- High quality V-belt for optimal power transmission
- Including limit switch for automatic shut-down at opening of the blade covers

TOP-PRICE!



Dynamically balanced cast iron flywheels for smooth run.



Tilttable working table from 0° to 45°, desired adjustment read off by a mm-scale.



Ergonomically mounted hand-wheels for adjustment of the blade tension or cutting height on the backside.



Easy adjustable aluminium rip fence with quick clamping system, read off the mm-scale by loupe.



The solid belt pulley and the high-quality V-belt ensure an optimal power transmission from the motor.



On/Off switch in accordance with the IP 54 standard with undervoltage release.



Optional available: CO-MATIC power feeder



Maintenance-free precision roller guide for optimal guiding of the bandsaw blade.

Technical data	HBS 400	HBS 450	HBS 510
Cutting width	380 mm	440 mm	480 mm
Cutting height	220 mm	345 mm	305 mm
Blade dimension	2950 x 16 x 0,52 - 4 TPI	3430 x 20 x 0,6 - 4 TPI	3500 x 25 x 0,62 - 3,5 TPI
Blade width	6 - 20 mm	10 - 32 mm	10 - 40 mm
Cutting speed	600 m/min	600 m/min	600 m/min
Table size	410 x 500	490 x 590 mm	490 x 590 mm
Table height	940 mm	940 mm	940 mm
Tilting table	0° to 45°	0° to 45°	0° to 45°
Dust extraction outlet	100 mm	100 mm	100 mm
Motor power output S ₁ 100%	1,5 kW (2,0 HP)	2,2 kW (3,0 HP)	2,2 kW (3,0 HP)
Motor power input S ₆ 40%	2,1 kW (2,8 HP)	3,0 kW (4,0 HP)	3,0 kW (4,0 HP)
Voltage	230 V or 400 V	230 V or 400 V	230 V or 400 V
Machine dimension (B x T x H)	760 x 880 x 1705 mm	930 x 880 x 1865 mm	930 x 880 x 1865 mm
Weight approx.	140 kg	170 kg	220 kg
Art. no.	11-4055B (230 V)	11-4060B (230 V)	11-4065B (230 V)
	11-4055 (400 V)	11-4060 (400 V)	11-4065 (400 V)
Price excl. VAT			

BERNARDO
www.bernardo.at
HOBBY

Standard accessories:

- Bandsaw blade
- Rip fence with loupe
- Mitre fence
- Cast iron flywheels
- 3-roller bandsaw blade guiding
- Push stick
- Tools

The wood bandsaws of the HBS-series satisfy through the amply sized working table and the cast iron flywheels. For the cost-conscious amateurs are these machines the ideal equipment.

HBS 400 / HBS 450 / HBS 510

Wood bandsaws



Optional accessories:

	Art. no.	excl. VAT
Bandsaw blade 2950 x 16 x 0,6 - 4 TPI for HBS 400	11-1005	
Bandsaw blade 3430 x 20 x 0,6 - 4 TPI for HBS 450	11-1006	
Bandsaw blade 3500 x 25 x 0,6 - 3,5 TPI for HBS 510	11-1008	
Universal mobile base MB 230	56-10700	

Wood bandsaws

HBS 600 E / HBS 700 E / HBS 800 E

- Cutting height adjustment via gear rack with mm-scale using a handwheel
- Flywheels out of cast iron with rubber coating and chip brush
- Serially with 2 dust extraction outlets (diam. 100 mm) for an optimal dust extraction
- Torsion-free machine body guarantees for a smooth and precise run
- Generously dimensioned cast iron table, tiltable from -5° to $+45^{\circ}$
- Inspection window with indication of the blade tension for the respective bandsaw blade width
- Easy adjustable aluminium rip fence with quick clamping system and integrated loupe
- Including limit switch for automatic shut-down at opening of the blade covers
- High-power drive motor allow handling of bigger workpieces

BERNARDO
www.bernardo.at
SEMIPROFESSIONAL



The flywheel with special rubber-coating ensure a smooth run and long life-span of the bandsaw blades.



The blade tension adjustment takes places using a handwheel and will be indicated by a diagram at the upper flywheel.



Including precision 3-roller bandsaw blade guiding over and under the table.



Inspection window for blade run and cutting height adjustment on the front side



The serially mitre fence is adjustable from -60° up to $+60^{\circ}$ and will be guided in the T-slot of the table

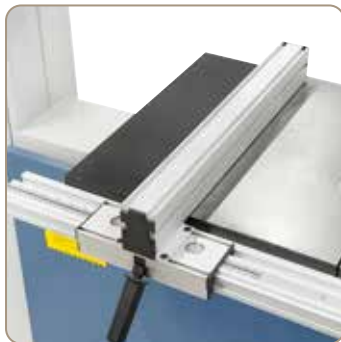

Easy adjustable aluminium rip fence with quick clamping system, read off the mm-scale by loupe.



Powerful drive motor also at continuous run, optimal dust extraction through the diam. 100 mm outlet.



Optional available: Carriage

Technical data	HBS 600 E	HBS 700 E	HBS 800 E
Cutting width	600 mm	700 mm	800 mm
Cutting height	430 mm	430 mm	470 mm
Blade dimension	4590 x 25 x 0,6 / 2 TPI	5020 x 38 x 0,65 - 2 TPI	5611 x 38 x 0,65 - 2 TPI
Blade width	19 - 38 mm	19 - 40 mm	19 - 50 mm
Cutting speed	1080 m/min	1080 m/min	1080 m/min
Table size	630 x 480 mm	640 x 500 mm	640 x 500 mm
Table extension	150 x 480 mm	150 x 500 mm	200 x 500 mm
Table height	910 mm	950 mm	1040 mm
Tilting table	-5° to $+45^{\circ}$	-5° to $+45^{\circ}$	-5° to $+45^{\circ}$
Dust extraction outlet	2x 100 mm	2x 100 mm	2x 100 mm
Motor power output S ₁ 100%	3,5 kW (4,7 HP)	4,0 kW (5,0 HP)	4,5 kW (6,1 HP)
Motor power input S ₆ 40%	4,8 kW (6,5 HP)	5,5 kW (7,5 HP)	5,8 kW (7,9 HP)
Voltage	400 V	400 V	400 V
Machine dimension (W x D x H)	1150 x 855 x 2140 mm	1300 x 900 x 2220 mm	1460 x 920 x 2470 mm
Weight approx.	239 kg	311 kg	366 kg
Art. no.	11-4016	11-4017	11-4018
Price excl. VAT			

**Best
Price**

Standard accessories:

- Bandsaw blade
- Rip fence with loupe
- Mitre fence
- Cast iron flywheels
- Precision 3-roller bandsaw blade guiding
- Motor incl. brake
- Push stick
- Tools

The wooden bandsaws of the HBS-E-series offer an optimal price-performance ratio and are the ideal machines for the price-conscious users.

HBS 700 E / HBS 800 E

HBS 600 E

Wood bandsaws

Motor with
brake



Optional accessories:

Bandsaw blade 4590 x 25 x 0,6 - 2 TPI f. HBS 600 E
Bandsaw blade 5020 x 38 x 0,65 - 2 TPI f. HBS 700 E
Bandsaw blade 5611 x 38 x 0,65 - 2 TPI f. HBS 800 E
Carriage

Art. no.	excl. VAT
11-1014	
11-1015	
11-1019	
56-1071	

BERNARDO[®]
www.bernardo.at

Wood bandsaws

HBS 400 N / HBS 460 N / HBS 500 N

- High-power drive motor allow handling of bigger workpieces
- Cutting height adjustment via gear rack with mm-scale using a handwheel
- Cutting speed adjustable with V-belt to the workpiece (HBS 400 N / HBS 460 N)
- Precise guided aluminium rip fence, removable on each position
- Working table with grounded surface and T-slot for the mitre fence
- Dynamically balanced flywheels for smooth run
- Easy bandsaw blade change using the quick clamping lever on the backside
- Inspection window on the front for checking the run of the bandsaw blade
- Generously dimensioned cast iron table, tiltable from -5° to $+45^{\circ}$

**Best
Price**



The blade tension adjustment takes places using a handwheel and will be indicated by a diagram at the upper flywheel .



Amply sized working table with grounded surface and T-slot for the mitre fence (standard)



Easy bandsaw blade changing using a quick clamping lever, the basic setting of the drive wheel will not be changed.



The integrated loupe at the rip fence afford an exact read-off of the adjusted cutting width, HBS 500 N additional with fine adjustment.



The desired cutting speed is adjustable with a V-belt at the lower flywheel (HBS 400 N / HBS 460 N).



Dynamically balanced cast iron flywheels for smooth run (HBS 500 N).



Ball bedded precision guides over and under the table guarantees a perfect bandsaw blade guiding (HBS 400 N / HBS 460 N).



Precision bandsaw blade guides above and under the table care for a smooth run of the bandsaw blade and ensure best cutting results (HBS 500 N).

Technical data	HBS 400 N	HBS 460 N	HBS 500 N
Cutting width	410 mm	465 mm	500 mm
Cutting height	260 mm	280 mm	350 mm
Blade dimension	3345 x 25 x 0,6 - 3 TPI	3607 x 25 x 0,6 - 3 TPI	4100 x 25 x 0,6 - 3 TPI
Blade width	9,5 - 37 mm	9,5 - 25,4 mm	19 - 38 mm
Cutting speed	420 / 840 m/min	420 / 840 m/min	1320 m/min
Table size	450 x 560 mm	480 x 630 mm	500 x 640 mm
Table height	890 mm	970 mm	920 mm
Tilting table	-5° to $+45^{\circ}$	-5° to 45°	-5° to 45°
Dust extraction outlet	2x 100 mm	2x 100 mm	2x 100 mm
Motor power output S ₁ 100%	2,2 kW (3,0 HP)	2,2 kW (3,0 HP)	3,5 kW (4,7 HP)
Motor power input S ₆ 40%	3,0 kW (4,0 HP)	3,0 kW (4,0 HP)	4,8 kW (6,5 HP)
Voltage	230 V or 400 V	230 V or 400 V	400 V
Machine dimension (W x D x H)	875 x 740 x 1740 mm	1050 x 800 x 1950 mm	1120 x 950 x 2000 mm
Weight approx.	132 kg	162 kg	280 kg
Art. no.	11-4019 (400 V) 11-4019B (230 V)	11-4020 (400 V) 11-4020B (230 V)	11-4025 (400 V)
Price excl. VAT			

BERNARDO[®]
SEMIPROFESSIONAL

**Quick clamping lever for
bandsaw blade change**

Our top models of the HBS-series are the optimal machines for the ambitious craftsmen. The models HBS 400 N and HBS 460 N comes standard with 2 cutting speeds. Further, these models allows a quick bandsaw blade changing using the quick clamping lever.

HBS 400 N / HBS 460 N / HBS 500 N

Wood bandsaws

Motor with brake



Standard accessories:

- Bandsaw blade
- Rip fence with loupe
- Mitre fence
- Aluminium flywheels (HBS 400 N / HBS 460 N)
- Cast iron flywheels (HBS 500 N)
- Ball-bedded bandsaw blade guiding (HBS 400 N / HBS 460 N)
- Precision 3-roller bandsaw blade guiding (HBS 500 N)
- Motor incl. brake (except HBS 400 N)
- Push stick
- Tools

Optional accessories:

- Bandsaw blade 3345 x 25 x 0,6 - 3 TPI f. HBS 400 N
- Bandsaw blade 3607 x 25 x 0,6 - 3 TPI f. HBS 460 N
- Bandsaw blade 4100 x 25 x 0,6 - 3 TPI f. HBS 500 N
- Carriage (HBS 460 N / HBS 500 N)

Art. no.	excl. VAT
11-1009	
11-1012	
11-1013	
56-1071	

Wood bandsaws

HBS 600 N / HBS 700 N / HBS 800 N

- Dynamically balanced flywheels for smooth run
- Cutting height adjustment via gear rack with mm-scale using a handwheel
- Working table with grounded surface and T-slot for the mitre fence
- Easy bandsaw blade change using the quick clamping lever on the backside
- Precise guided aluminium rip fence, removable on each position
- Inspection window on the front for checking the run of the bandsaw blade
- Generously dimensioned cast iron table, tiltable from -5° to $+45^{\circ}$
- High-power drive motor allow handling of bigger workpieces
- Professional wooden bandsaw – heavy self-weight for maximum smoothness

BERNARDO
SEMIPROFESSIONAL



The flywheel with special rubber-coating ensure a smooth run and long life-span of the bandsaw blades.



Easy bandsaw blade changing using a quick clamping lever, the basic setting of the drive wheel will not be changed.



Robust tilting device out of cast iron. The adjustment takes place by handwheel and can be read on the scale.



The integrated loupe at the rip fence afford an exact read-off of the adjusted cutting width.



Powerful drive motor with brake function, optimal dust extraction through the diam. 100 mm outlet.



Amply sized working table with grounded surface and T-slot for the mitre fence (standard)



Precision bandsaw blade guides above and under the table care for a smooth run of the bandsaw blade and ensure best cutting results

Technical data	HBS 600 N	HBS 700 N	HBS 800 N
Cutting width	600 mm	700 mm	800 mm
Cutting height	435 mm	430 mm	460 mm
Blade dimension	4590 x 25 x 0,6 - 3 TPI	5020 x 38 x 0,65 - 2 TPI	5611 x 38 x 0,6 - 2 TPI
Blade width	19 - 38 mm	19 - 50 mm	19 - 50 mm
Cutting speed	1560 m/min	1560 m/min	1080 m/min
Table size	610 x 700 mm	900 x 700 mm	900 x 700 mm
Table height	910 mm	930 mm	1050 mm
Tilting table	-5° to 45°	-5° to $+45^{\circ}$	-5° to $+45^{\circ}$
Dust extraction outlet	2x 100 mm	2x 100 mm	2x 100 mm
Motor power output S_1 100%	4,0 kW (5,5 HP)	4,0 kW (5,5 HP)	5,5 kW (7,5 HP)
Motor power input S_6 40%	5,5 kW (7,5 HP)	5,5 kW (7,5 HP)	7,1 kW (9,7 HP)
Voltage	400 V	400 V	400 V
Machine dimension (W x D x H)	1230 x 1000 x 2120 mm	1500 x 1000 x 2230 mm	1600 x 1000 x 2480 mm
Weight approx.	330 kg	370 kg	524 kg
Art. no.	11-4030	11-4032	11-4033
Price excl. VAT			

Quick clamping lever for bandsaw blade change

Standard accessories:

- Bandsaw blade
- Rip fence with loupe
- Mitre fence
- Cast iron flywheels
- Precision-3-roller bandsaw blade guiding
- Motor incl. brake
- Push stick
- Tools

Our top models of the HBS-series are the optimal machines for the professional user. These models are serially equipped with a brake motor, a precision 3-roller bandsaw blade guiding as well as cast iron flywheels. Further, these models allow a quick bandsaw blade changing using the quick clamping lever.

HBS 600 N / HBS 700 N / HBS 800 N

Wood bandsaws

Motor with
brake



Optional accessories:

Bandsaw blade 4590 x 25 x 0,6 - 3 TPI f. HBS 600 N
 Bandsaw blade 5020 x 38 x 0,9 - 2 TPI f. HBS 700 N
 Bandsaw blade 5611 x 38 x 0,6 - 2 TPI f. HBS 800 N
 Carriage

Art. no.	excl. VAT
11-1014	
11-1015	
11-1019	
56-1071	

Log bandsaws

BBS 650 B BBS 650 E

- Dynamically balanced, grey cast drive wheels allow for a smooth run
- Suitable for processing logs into boards, planks and beams
- Bed extensions are optionally available for various cutting lengths
- Suitable for cutting of soft as well as hard timber logs
- Manual adjustment of feed and height of saw unit
- Comes complete with coolant container and dosage valve for optimal lubrication and cooling of bandsaw blade
- Adjustable fences allow for easy clamping of timber logs
- Saw unit is fixed and guided from both sides



Precise guided bandsaw blade and coolant supply for optimal cutting results



Crank allows for convenient height adjustment of saw unit – scale ensures easy readout



Four rollers on ball bearings guarantee for a vibration free run of the saw unit.

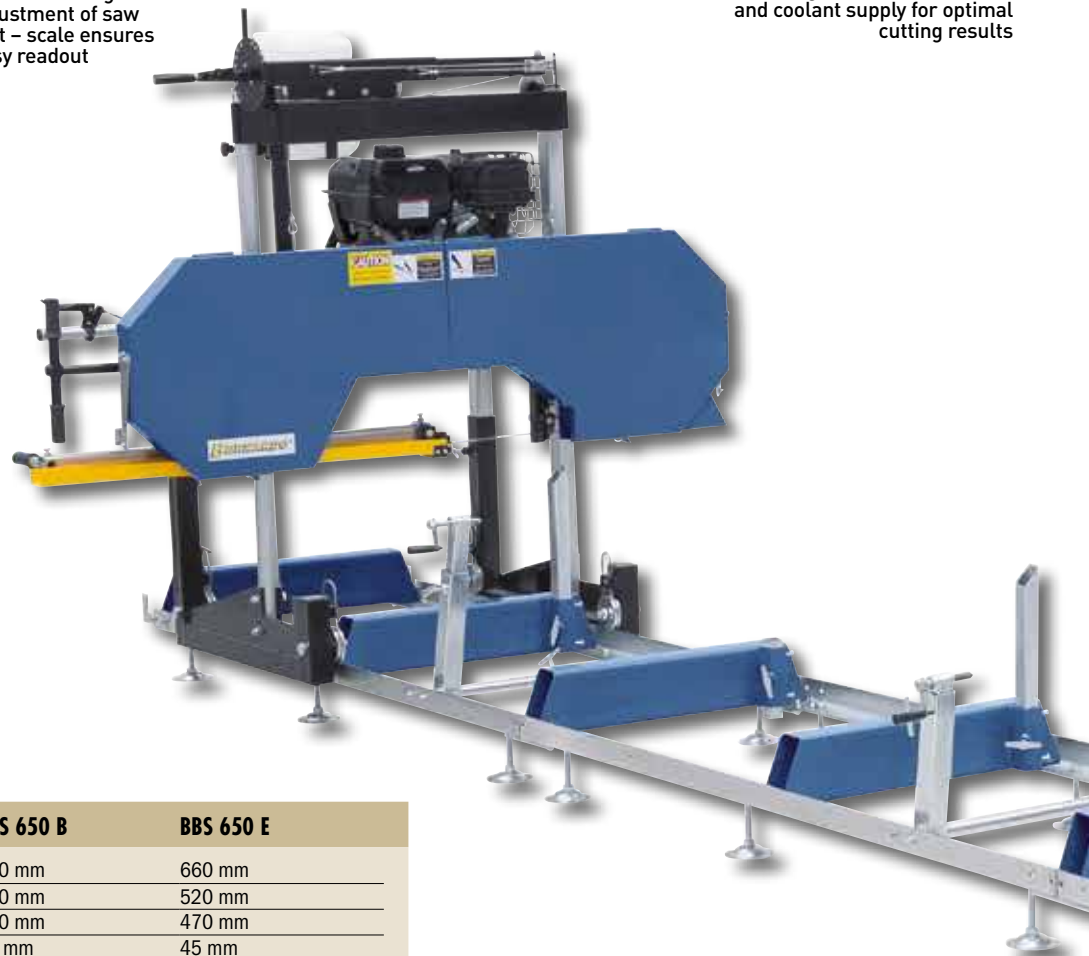

Technical data

	BBS 650 B	BBS 650 E
Max. log diameter	660 mm	660 mm
Max. board width	520 mm	520 mm
Max. cutting height	470 mm	470 mm
Min. cutting height	45 mm	45 mm
Max. cutting depth	180 mm	180 mm
Cutting length basic version	5100 mm	5100 mm
Extension (Option)	1950 mm	1950 mm
Max. cutting length	unlimited	unlimited
Min. cutting length	1000 mm	1000 mm
Feed	manual	manual
Diameter of flywheel	480 mm	480 mm
Width of flywheel	22 mm	22 mm
Bandsaw blade	3650 x 34 x 1,1 mm	3650 x 34 x 1,1 mm
Bandsaw blade speed	1200 m/min	1200 m/min
Motor power	10,0 KW (14 HP)	7,5 kW (10 HP)
Voltage	-	400 V
Machine dimension (W x H x L – basic version)	1800 x 1700 x 6505 mm	1800 x 1700 x 6505 mm
Weight approx.	380 kg	380 kg
Weight of extension	55 kg	55 kg
Art. no.	14-1303	14-1304

Standard accessories:

- Bandsaw blade HSS 3650 x 34 x 1,1 mm
- Electric motor with star delta start-up (BBS 650 E)
- Gasoline motor (BBS 650 B)
- Bed extension for cutting length max. 5,1 m
- 2 pcs. log clamping devices
- Coolant tank

The BBS series of log bandsaws are available with either electronic drive or gasoline engine. The electric version is mainly used as a stationary machine; the gasoline drive model option is perfectly suitable for transport between sites. The brilliant price to benefit ratio makes this model perfect for agricultural purposes, forestry, carpentry etc.

BBS 650 B BBS 650 E



Available at 2 drive options: 10 HP electric motor or 14 HP gasoline engine with starter cable.



Tiltable covers allow for easy bandsaw blade change.



Picture shows electronic panel and push stick for manual feed (height adjustable).

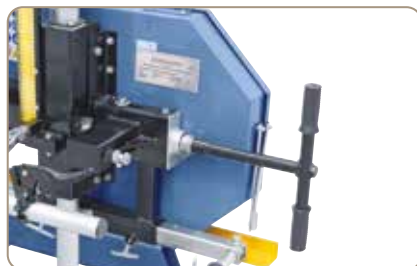

User-friendly tensioning of bandsaw blade, easy to access.

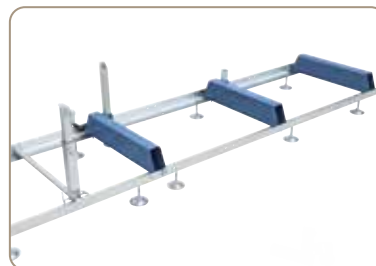

Optional extension units allow for various cutting lengths (each 1,95 m length).

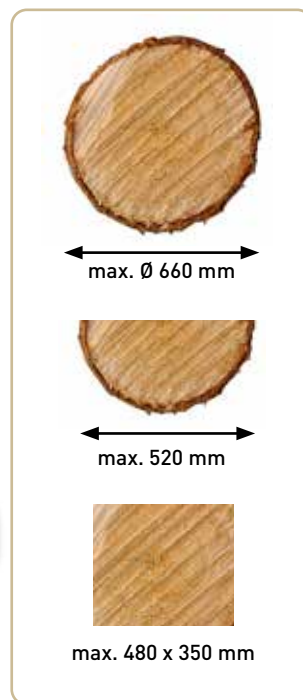

Optional accessories:

Bandsaw blade 3650 x 34 x 1,1 mm - 2 TPI

Art. no. 11-1050
excl. VAT

Optional accessories:

Bed extension 1950 mm

Art. no. 14-1305
excl. VAT

Log bandsaw

BBS 780 B

- Dynamically balanced, grey cast drive wheels allow for a smooth run
- Suitable for processing logs into boards, planks and beams
- Bed extensions are optionally available for various cutting lengths
- Suitable for cutting of soft as well as hard timber logs
- Manual adjustment of feed and height of saw unit
- Comes complete with coolant container and dosage valve for optimal lubrication and cooling of bandsaw blade
- Adjustable fences allow for easy clamping of timber logs
- Saw unit is fixed and guided from both sides



Crank allows for convenient height adjustment of saw unit – scale ensures easy readout

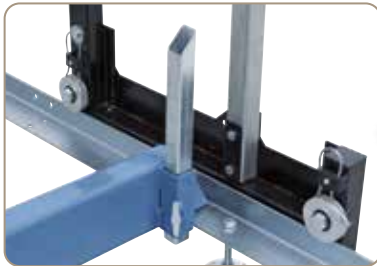

Four rollers on ball bearings guarantee for a vibration free run of the saw unit.



Precise guided bandsaw blade and coolant supply for optimal cutting results

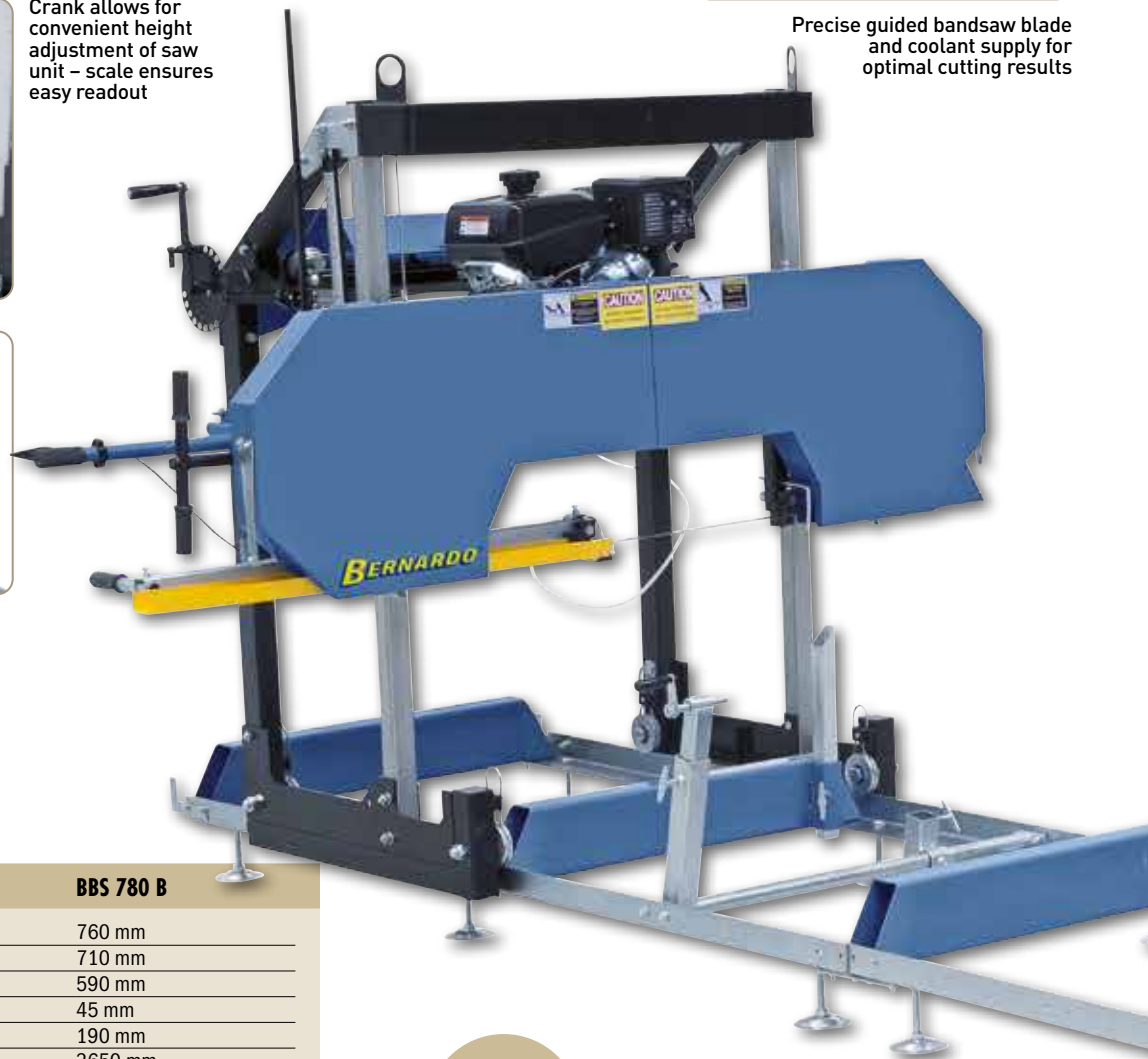

Technical data

BBS 780 B

Max. log diameter	760 mm
Max. board width	710 mm
Max. cutting height	590 mm
Min. cutting height	45 mm
Max. cutting depth	190 mm
Cutting length basic version	3650 mm
Extension (Option)	1830 mm
Max. cutting length	unlimited
Min. cutting length	1150 mm
Feed	manual
Diameter of flywheel	480 mm
Width of flywheel	24 mm
Bandsaw blade	4010 x 34 x 1,1 mm
Bandsaw blade speed	1200 m/min
Motor power	10,0 KW (14 HP)
Machine dimension (W x H x L - basic version)	2300 x 1900 x 4540 mm
Weight approx.	367 kg
Weight of extension	50 kg
Art. no.	14-1312

**Best
Price**

**Gasoline motor Kohler
Command Pro CH 440**

Standard accessories:

- Bandsaw blade HSS 4010 x 34 x 1,1 mm
- Gasoline motor Kohler Command Pro CH 440
- 2 pcs. log clamping devices
- Coolant tank

The log band saw BBS 780 B is equipped with a 14 HP Kohler Command Pro CH 440 gasoline engine and therefore also suitable for mobile use. The brilliant price to benefit ratio makes this model perfect for agricultural purposes, forestry, carpentry etc.

BBS 780 B



14 HP gasoline engine Kohler Command Pro CH 440 with starter cable.



The flywheel with special rubber-coating ensure a smooth run and long life-span of the bandsaw blades.



Tiltable covers allow for easy bandsaw blade change.



Combined roll-carbide inserts for ideal bandsaw blade guiding ensure best cutting results.



User-friendly tensioning of bandsaw blade, easy to access.



Optional extension units allow for various cutting lengths (each 1,83 m length).

powder coated



BERNARDO
www.bernardo.at
SEMIPROFESSIONAL

NEW



max. Ø 760 mm



max. 710 mm



max. 540 x 435 mm

Optional accessories:

Bandsaw blade 4010 x 34 x 1,1 mm - 2 TPI

Art. no. 11-1051
excl. VAT

Optional accessories:

Bed extension 1830 mm

Art. no. 14-1313
excl. VAT

Your dealer

BERNARDO[®]
www.bernardo.at

PWA Handelsges.m.b.H.
4020 Linz | Nebingerstraße 7a | Austria
phone: +43.732.66 40 15 | fax: +43.732.66 40 15-9
e-mail: bernardo@pwa.at | www.bernardo.at

Imprint:
All rights reserved – reproduction of images or texts or parts of these is strictly prohibited unless prior arrangements are made. Subject to technical and optical amendments. Product specifications subject to change without notice. Not responsible for printing errors or mistakes. Machines are partly displayed with optional extras. Prices subject to change. Prices in Euros, ex works (Linz, Austria), excl. any taxes. Edition 01/2024.